

RF/ BB Connections

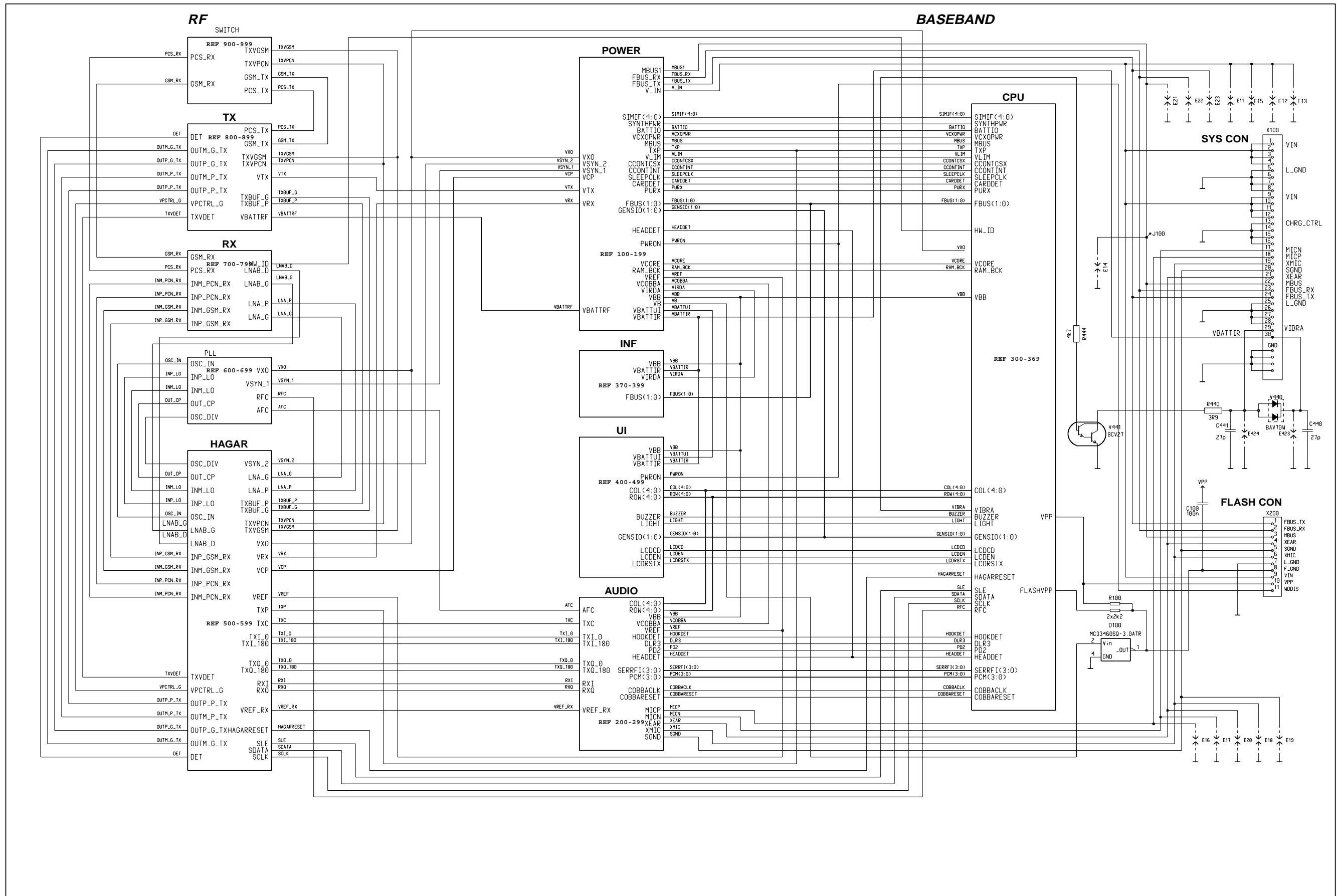

Power

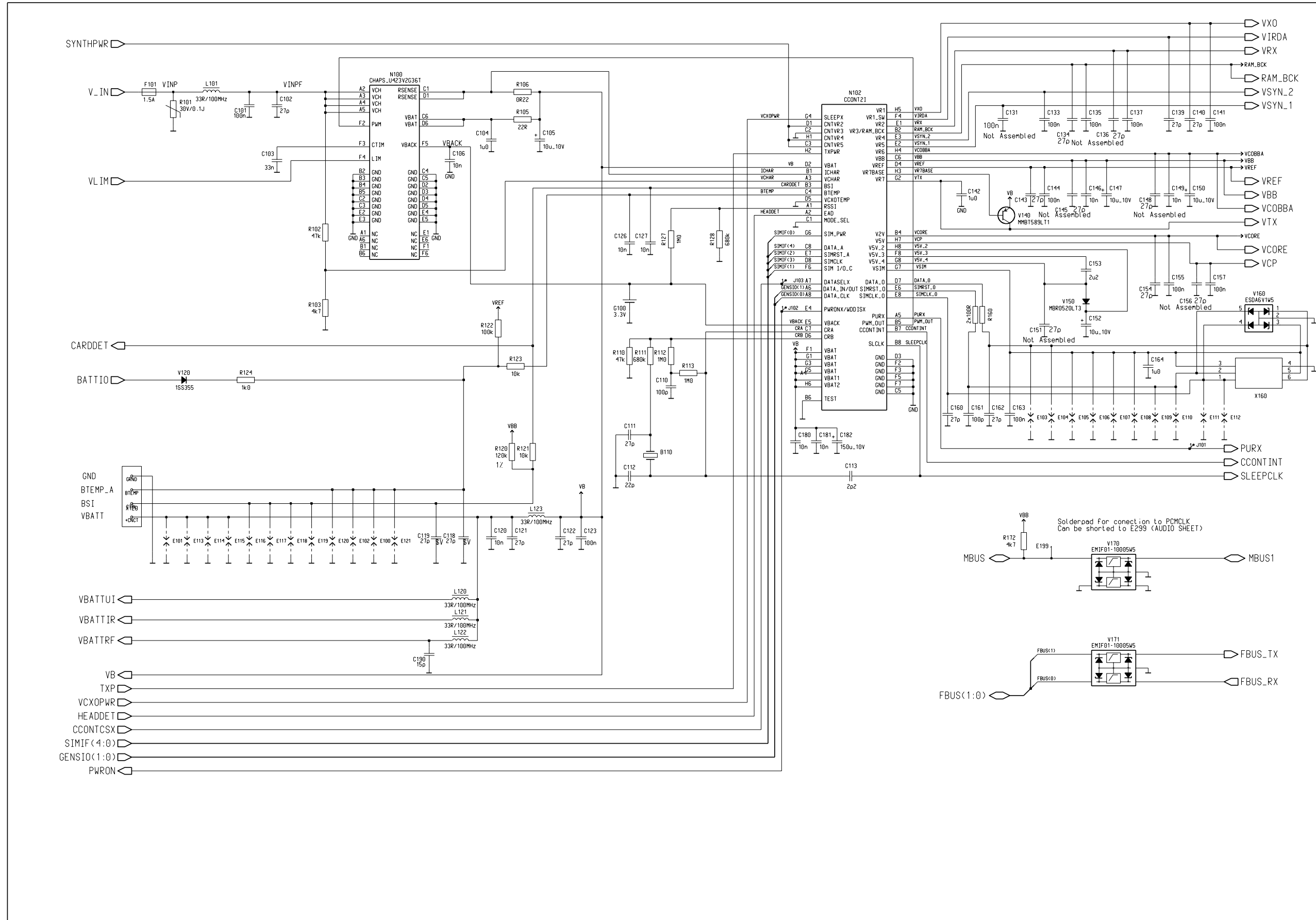

CPU

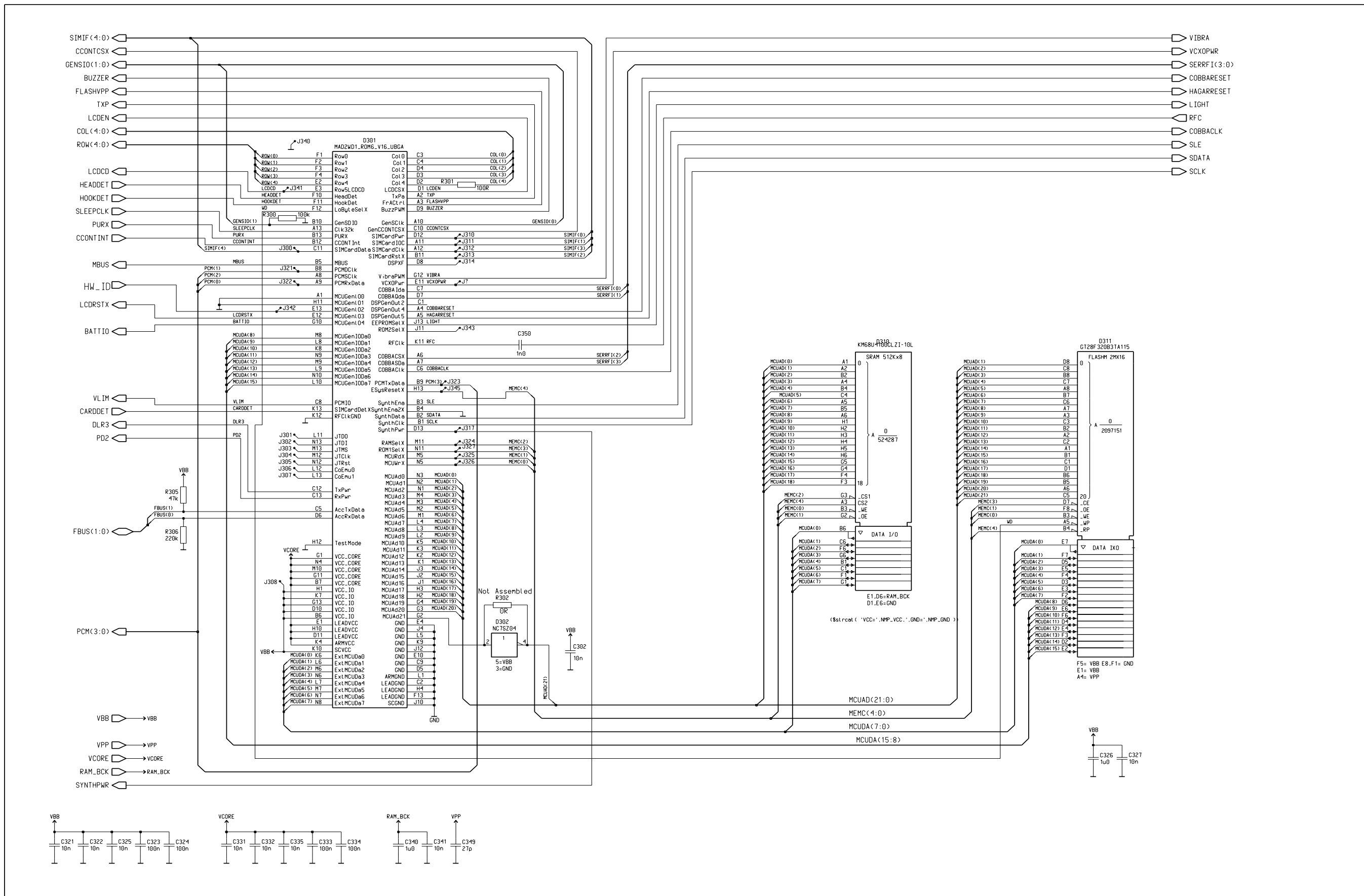

Hagar

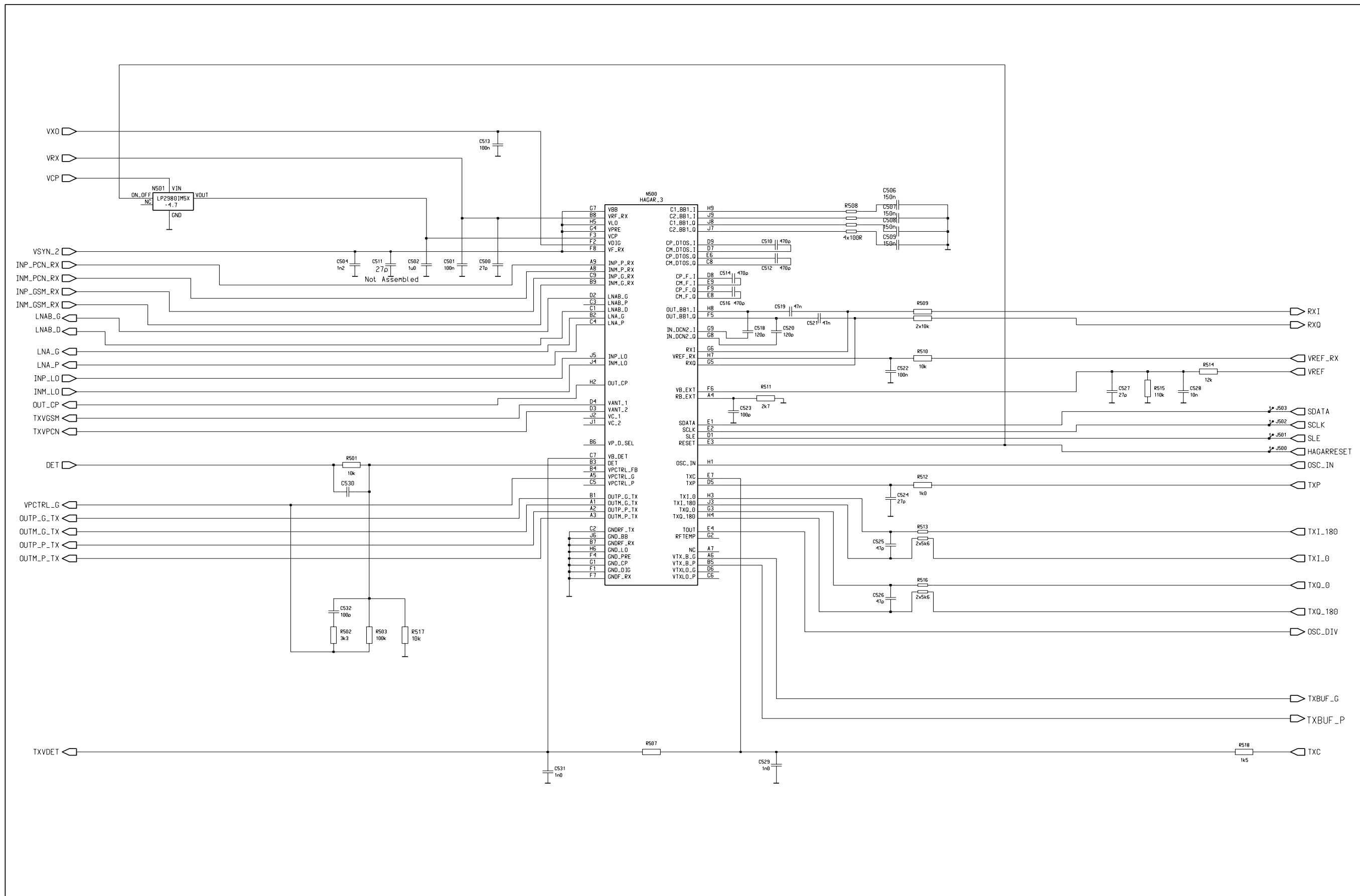

Switch

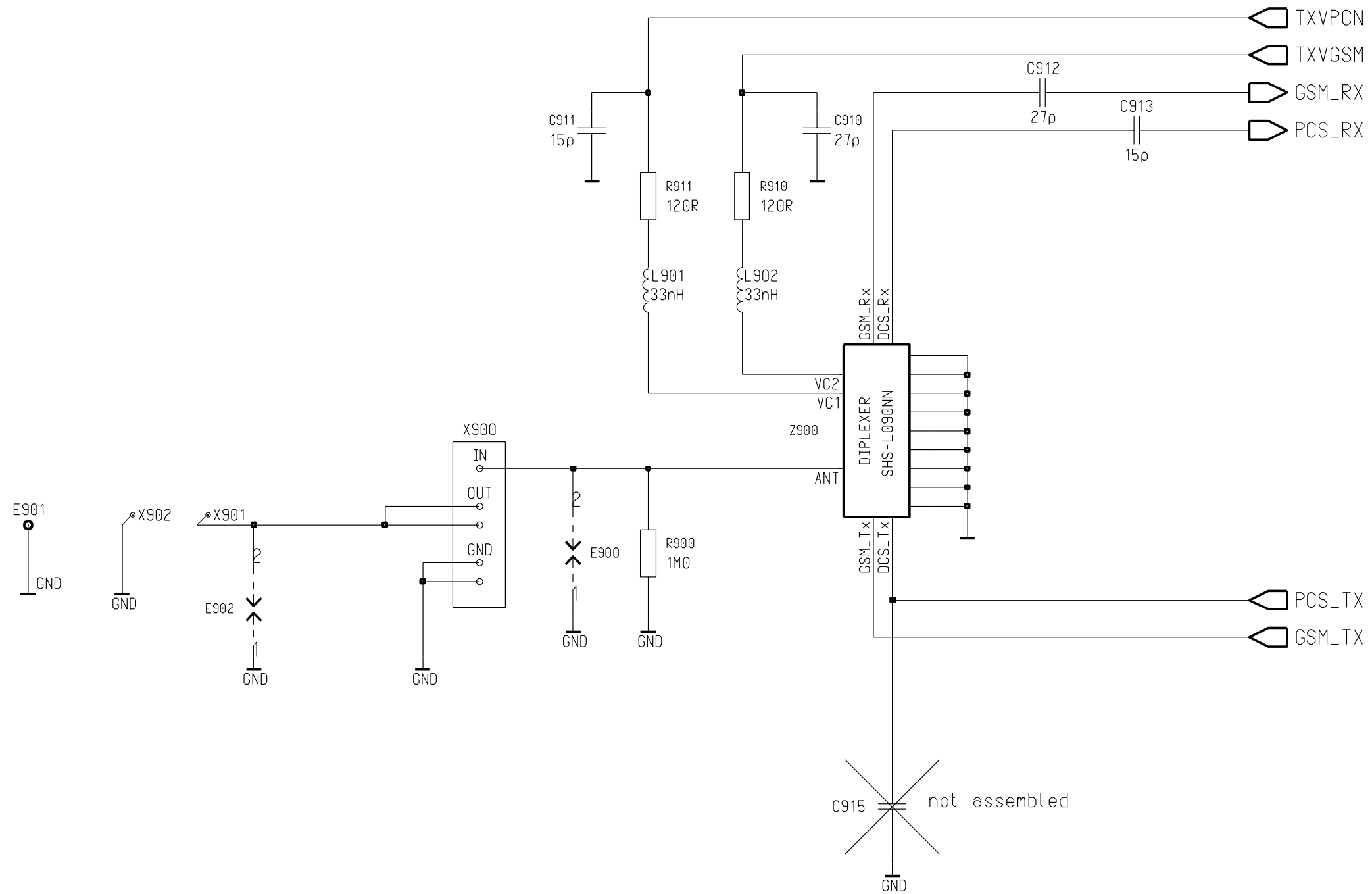

Audio

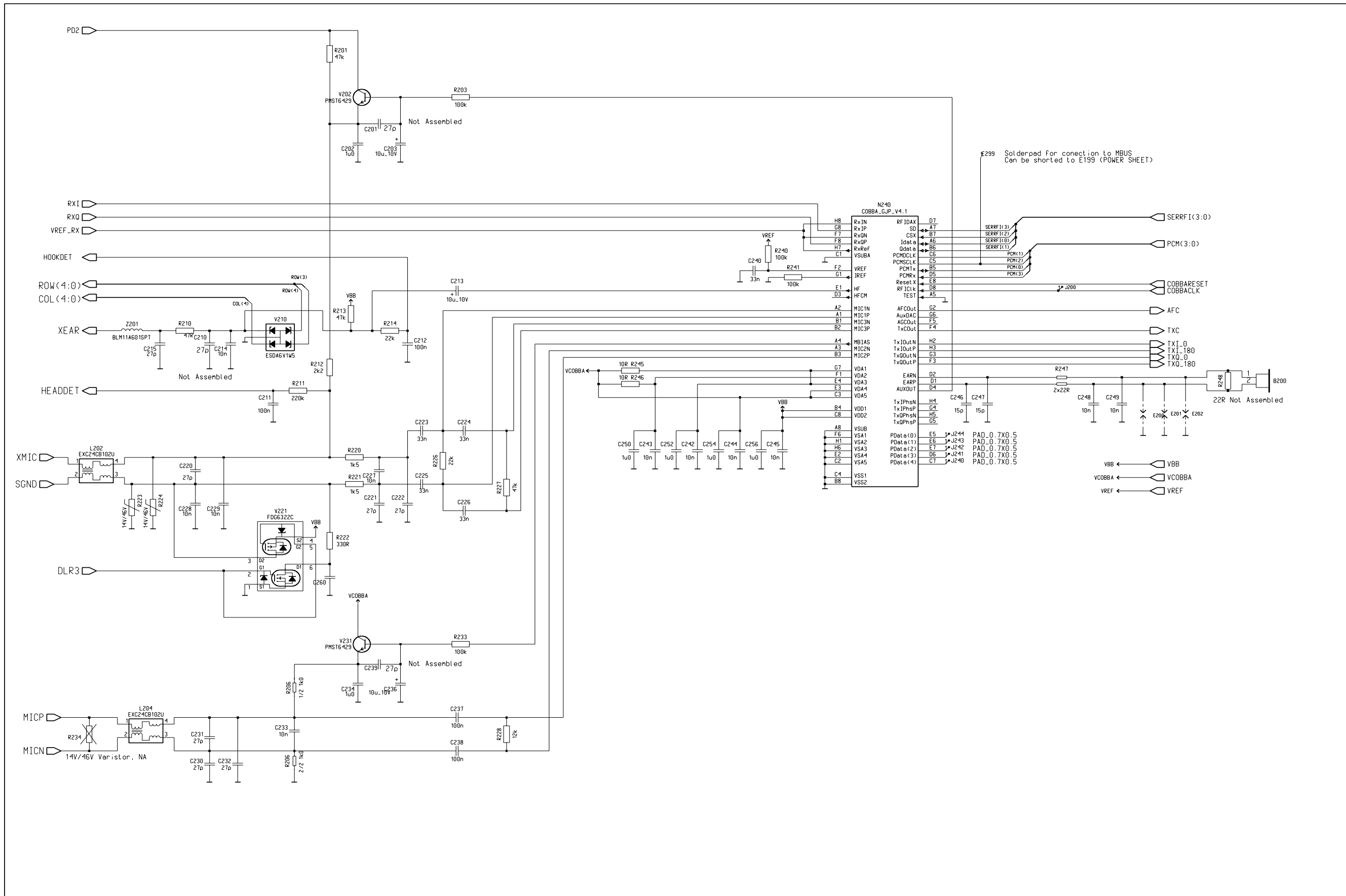

RX

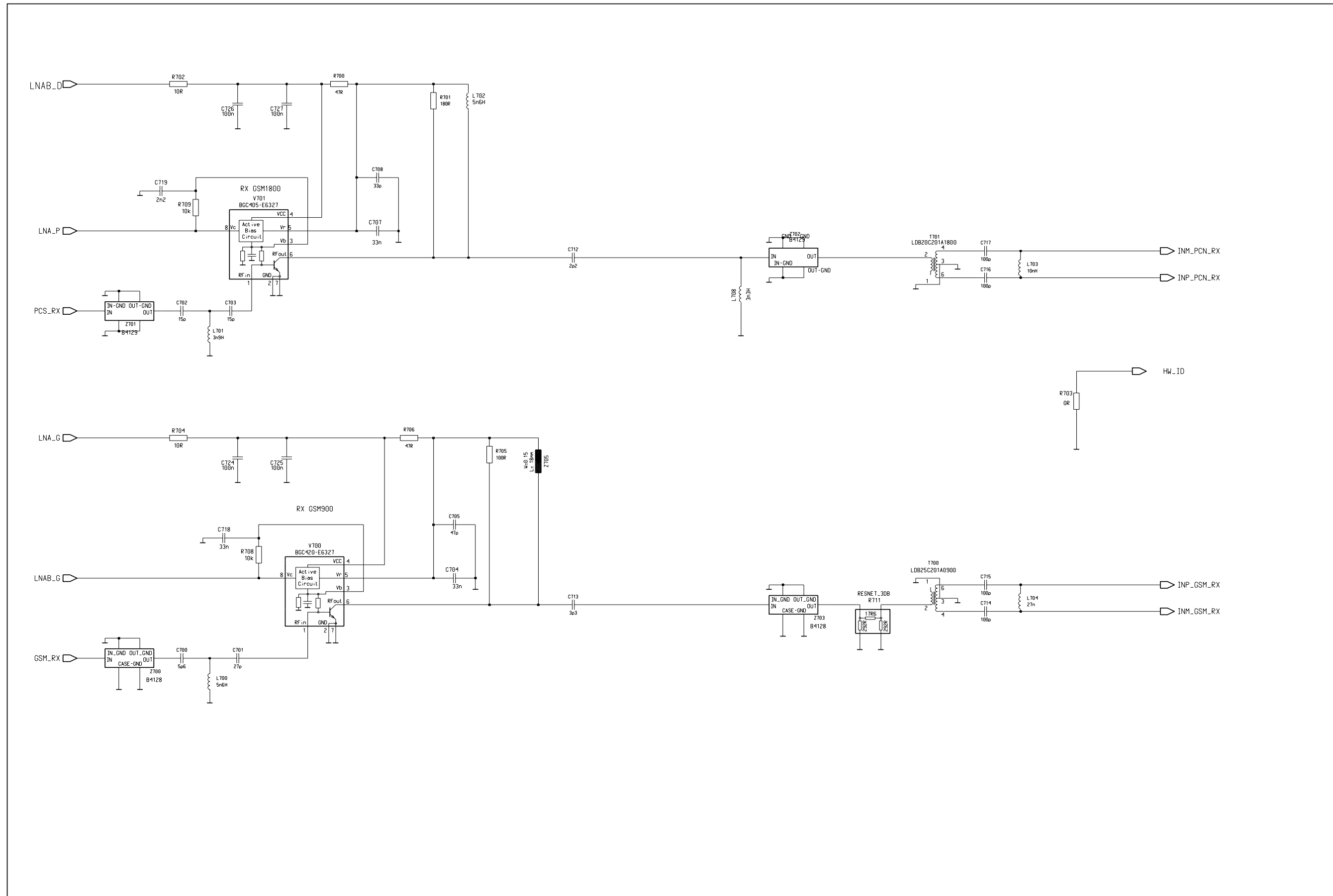

PLL

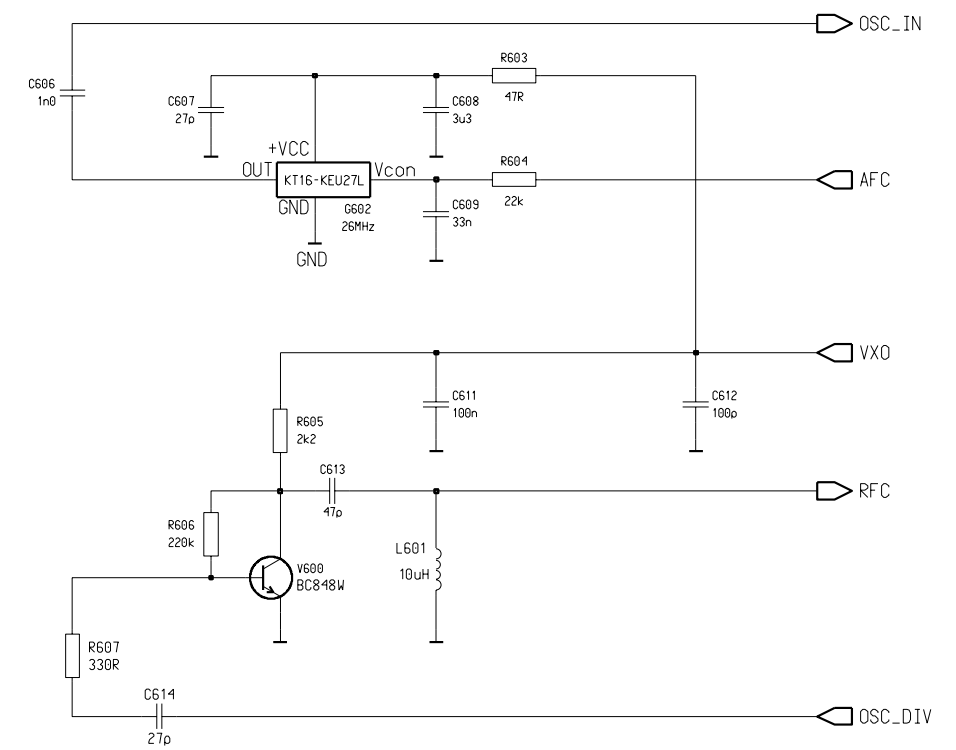
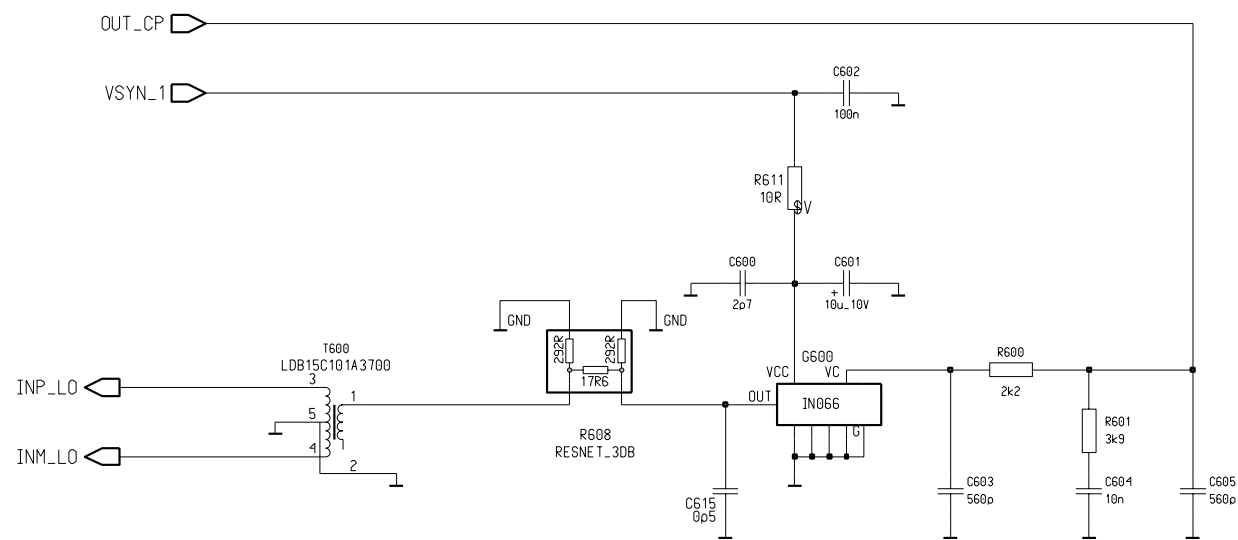



Infrared

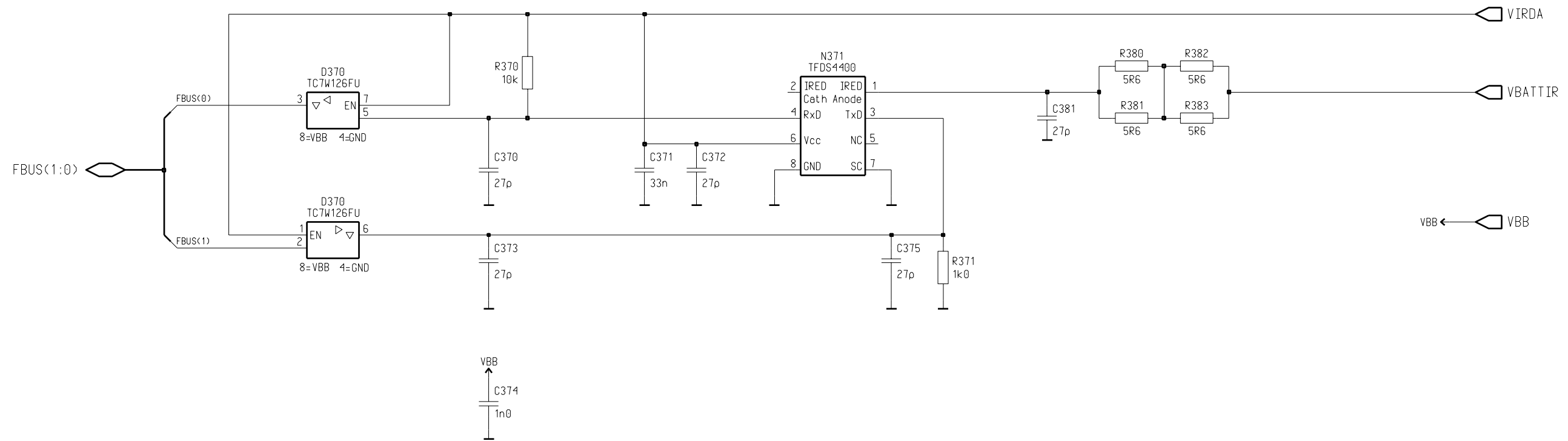

TX

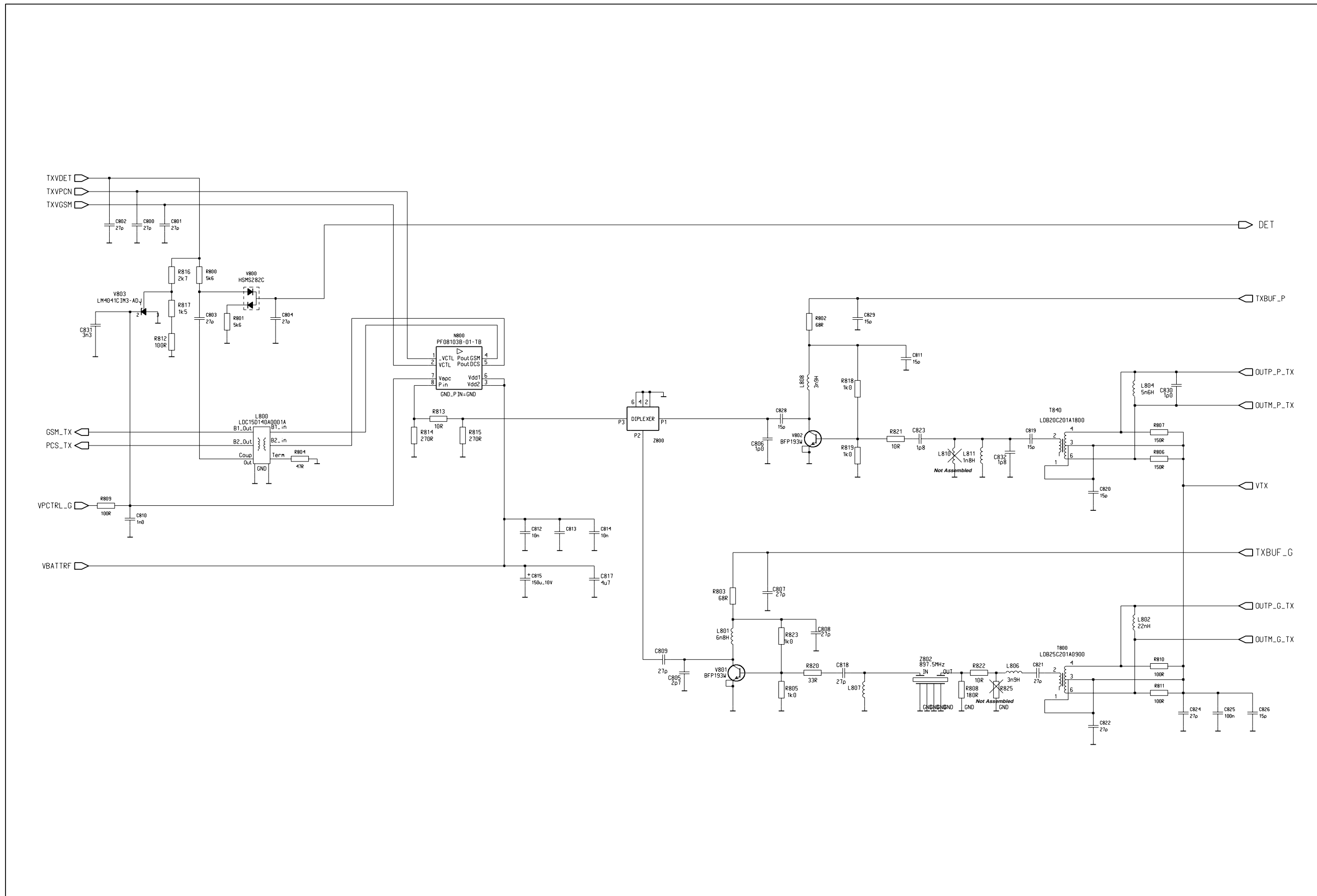

UI

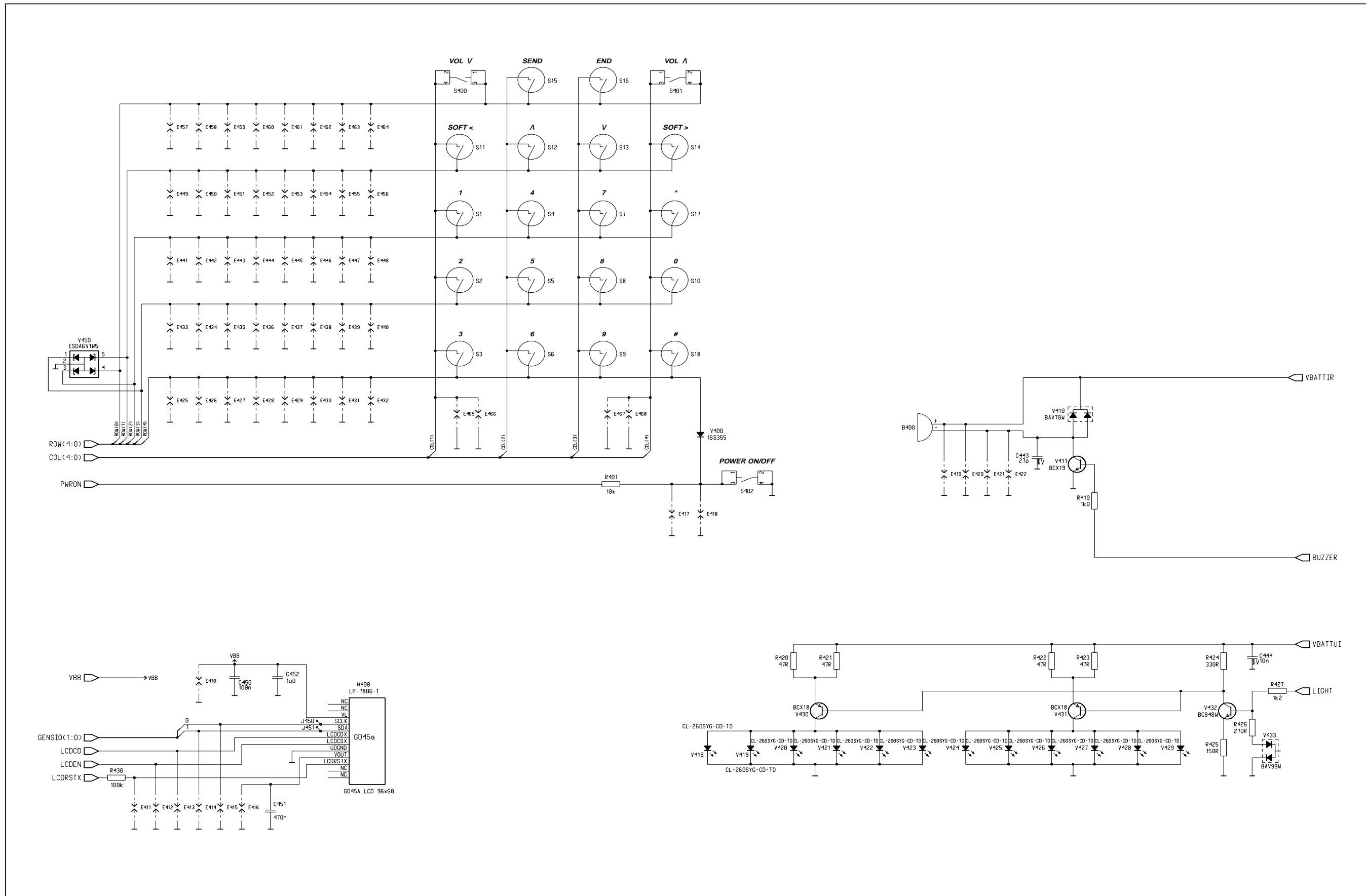

Layouts

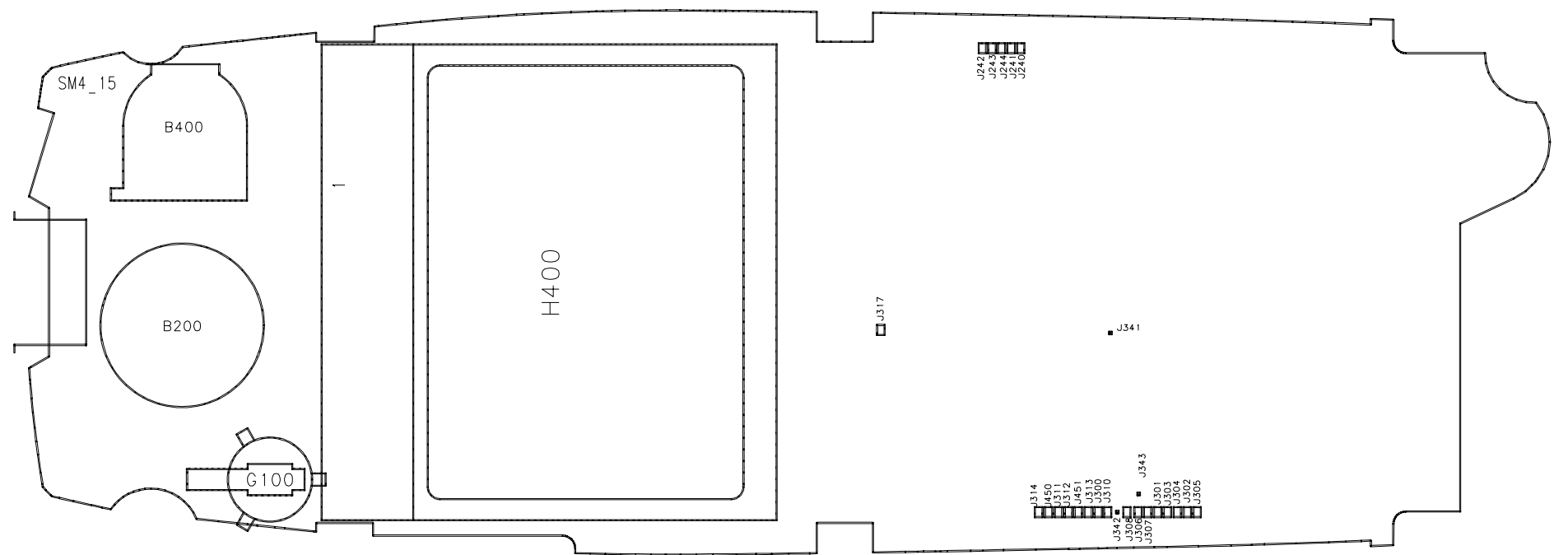
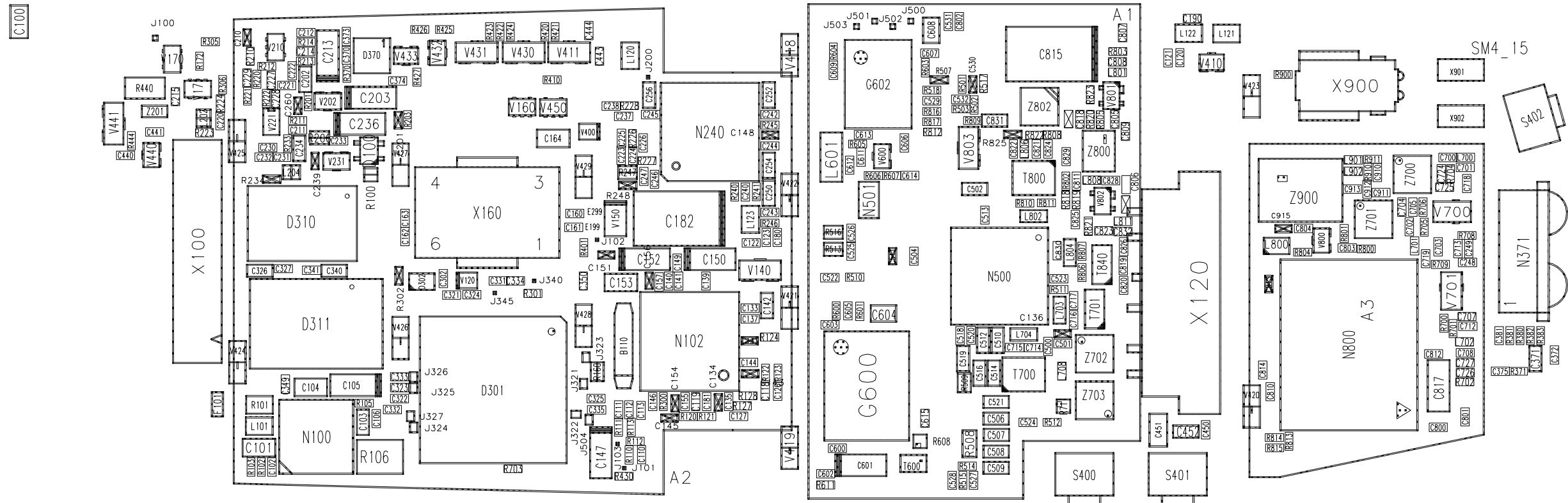

Shields

